

International Astronomical Union

Standards Of Fundamental Astronomy

SOFA Tools for Earth Attitude

Software version 4
Document revision 1.0

<http://www.iau-sofa.rl.ac.uk/>

2007 August 1

IAU STANDARDS OF FUNDAMENTAL ASTRONOMY REVIEW BOARD

John Bangert	United States Naval Observatory
Wim Brouw	University of Groningen
Anne-Marie Gontier	Paris Observatory
Catherine Hohenkerk	Her Majesty's Nautical Almanac Office
Wen-Jing Jin	Shanghai Observatory
Zinovy Malkin	Inst. Appl. Astron., St Petersburg
Dennis McCarthy	United States Naval Observatory
Jeffrey Percival	University of Wisconsin
Patrick Wallace (chair)	Rutherford Appleton Laboratory

Contents

1	INTRODUCTION	1
1.1	The SOFA software	1
1.2	Quick start	1
1.3	Abbreviations	1
2	CELESTIAL COORDINATES	3
2.1	Stellar directions	3
2.2	Precession-nutation	3
2.3	Evolution of celestial reference systems	4
2.4	The IAU 2000 changes	7
2.5	Frame bias	7
2.6	CIO and TIO	8
2.7	Equation of the origins	8
2.8	Equinox versus CIO	8
2.9	The celestial to terrestrial transformation	9
3	SOFA EARTH ATTITUDE MODELS	10
3.1	Classical precession	10
3.2	Classical nutation	11
3.3	The CIP X, Y	11
3.4	The CIO locator, s	12
3.5	Polar motion	12
3.6	Earth rotation	12
3.7	Fundamental arguments	14
3.8	Supporting routines	14
4	CURRENT MODELS	15
4.1	Canonical basis	15
4.2	SOFA routines	16
5	EXAMPLES	17
5.1	Preliminaries	18
5.2	IAU 1976/1980/1982/1994, equinox based	20
5.3	IAU 2000A, CIO based, using classical angles	21
5.4	IAU 2000A, equinox based, using classical angles	23
5.5	IAU 2006/2000A, CIO based, using classical angles	24
5.6	IAU 2006/2000A, CIO based, using X, Y series	26
6	FURTHER READING	27
	APPENDIX	

blank page

1 INTRODUCTION

1.1 The SOFA software

SOFA stands for *Standards Of Fundamental Astronomy*. The SOFA software is a collection of Fortran 77 subprograms that implement official IAU algorithms for fundamental-astronomy computations. At the present time the SOFA subprograms comprise 107 “astronomy” routines supported by 52 “vector/matrix” routines.

The basic documentation for the SOFA collection is terse, consisting of (i) detailed preamble comments in the individual routines and (ii) classified and alphabetic lists of subroutine calls. For an important subset of the SOFA routines, namely those concerned with the Earth’s orientation and rotation, the present paper supplements the basic documentation with descriptive material and cookbook examples.

1.2 Quick start

Expert readers may wish to start with *Examples*, Section 5. Anyone already familiar with the elementary concepts can safely omit the introductory material in Section 2. Those interested in only the latest models can also omit Section 3, which has a large historical component, and start with *Current Models*, Section 4.

1.3 Abbreviations

BCRS	barycentric celestial reference system
CIO	celestial intermediate origin
CIP	celestial intermediate pole
CIRS	celestial intermediate reference system
EE	equation of the equinoxes
EMB	Earth-Moon barycenter
EO	equation of the origins
FK4	fourth fundamental catalog
FK5	fifth fundamental catalog
GCRS	geocentric celestial reference system
GMST	Greenwich mean sidereal time
GST	Greenwich (apparent) sidereal time
IAU	international astronomical union
ICRS	international celestial reference system
IERS	international Earth rotation and reference systems service
ITRS	international terrestrial reference system
J2000	2000 January 1.5 (in some specified time scale)
NPB	nutations, precession and frame bias
SOFA	standards of fundamental astronomy
ST	sidereal time

TIO	terrestrial intermediate origin
TIRS	terrestrial intermediate reference system
TT	terrestrial time
UT	universal time UT1
UTC	coordinated universal time
VLBI	very long baseline interferometry

2 CELESTIAL COORDINATES

2.1 Stellar directions

Specifying the geometric or apparent direction to a star (or some other body) involves a number of factors: what type of coordinates, the reference triad (the choice of pole and longitude zero), what sort of direction, where the observer is located. The existing SOFA software concentrates on the first and second of these, providing definitive implementations of IAU models for precession-nutation and Earth rotation, supported by tools for manipulating spherical and vector coordinates. However, SOFA does not at present cover gravitational deflection, aberration, diurnal parallax, refraction and so on, leaving these aspects to the application writer.

SOFA’s transformation capabilities include not only the latest and most accurate methods but also a selection of former standards. Figures 1 and 2 show how some of the systems of celestial coordinates are related, to one another and to the direction in which a celestial source actually appears in the sky. Figure 1 is for the classical system of *mean places*, found in star catalogs and papers prior to the introduction of the International Celestial Reference System (ICRS); Figure 2 begins with ICRS coordinates and represents modern practices. At the bottom of each Figure is the *observed* $[Az, El]$, where a perfect theodolite would be pointed to see the source; and in the bodies of the two diagrams are the intermediate processing steps and coordinate systems.

To help understand these diagrams, and the supporting SOFA routines, we will review the coordinate systems involved, the astronomical phenomena that affect them and the different ways in which celestial coordinates can be managed.

2.2 Precession-nutation

We recall that the familiar *right ascension* and *declination*, $[\alpha, \delta]$, are the names of the longitude and latitude coordinates in a spherical polar system based on the Earth’s axis of rotation. The (classical) zero point of α is the intersection of the *celestial equator* and the *ecliptic* (the apparent path of the Sun through the year) where the Sun moves into the northern hemisphere. This point is called the *first point of Aries*, or the *equinox*. This simple picture is complicated by the influence on the Earth’s orbit and orientation of the gravitational fields of the solar-system bodies: as a result of these influences neither the equator nor the ecliptic is fixed with respect to the distant background, and consequently a star’s $[\alpha, \delta]$ coordinates are constantly changing.

The slow and large-scale effects are classically referred to as *precession*.

The phenomenon is further divided into *precession of the equator* and *precession of the ecliptic*, corresponding with the classical terms “luni-solar precession” which comes from the motion of the equator, and “planetary precession” which comes from the motion of the ecliptic.

The precession of the equator is caused by the torque exerted on the distorted and spinning Earth by tidal forces from the Moon (mainly) and Sun, with tiny additional contributions from the planets. The result is that the Earth’s rotation axis sweeps out a cone centered on the ecliptic pole, completing one revolution in about 26,000 years.

The precession of the ecliptic is caused by the influence on the Earth's orbital motion of the tidal forces from the planets. The effect is a slow (0".5 per year) secular rotation of the ecliptic about a slowly-moving diameter.

The ever-changing gravity gradient in which the Earth is immersed leads to a precessional motion that is itself constantly varying. However, the main 26,000-year component is on such a grand scale that it dwarfs the remaining terms, the biggest of which has an amplitude of only 11" and a period of about 18.6 years. This difference of scale makes it convenient to treat these two components of the motion separately, the smaller part being called *nutaton*. Thus precession and nutation are simply different frequency components of a single physical phenomenon.

The models for precession-nutation come from a combination of observation and theory, and are subject to continuous refinement. In recent decades, nutation models in particular have become quite elaborate; the IAU 1980 nutation model provided by the SOFA routine `iau_NUT80` comprises only 106 terms in each of ψ (longitude) and ϵ (obliquity), from 100 μas upwards in amplitude whereas the IAU 2000A nutation model, implemented in the routine `iau_NUT00A`, requires 1365 terms, some as small as 0.1 μas .

2.3 Evolution of celestial reference systems

Classical text-books use reference systems that are based on the celestial equator and the ecliptic, with the equinox as the zero point for right ascension. This simple geometrical picture is familiar, comfortable and works well for ordinary low-precision applications such as describing astronomical phenomena. However, when applied to more precise problems, complications arise. The Earth's pole (and hence equator) is in constant motion because of precession, nutation and polar motion; the ecliptic is a somewhat ill-defined concept and is itself constantly changing because of planetary perturbations. Using these moving planes in high-precision applications such as VLBI or pulsar timing became extremely complicated, and by the end of the 20th century the recommended procedures had changed:

1. The International Celestial Reference System was introduced, fixing the coordinate triad with reference to very distant objects. Although ICRS coordinates are close to FK5 J2000 mean places, this alignment was made merely for convenience, providing a degree of continuity. The ICRS is completely independent of the rotation and motion of the Earth: a given star has ICRS coordinates that are essentially fixed, changing only as a consequence of the star's own motion through space. In addition to the ICRS itself, new barycentric (BCRS) and geocentric (GCRS) celestial reference systems were introduced, to describe the relationship between different choices of space-time coordinates. These different systems are intimately related to the changing apparent direction of the light ray from the star as seen by different observers. As can be seen from Figure 2, BCRS coordinates apply to the star position once space motion has been taken into account; the apparent direction of the star as seen by a terrestrial observer is affected by parallax, light deflection by the Sun (and planets) and aberration, the result being expressed in GCRS coordinates. In effect, ICRS, BCRS and GCRS share the same orientation, and it is only once precession-nutation is considered that axes with a different orientation arise.

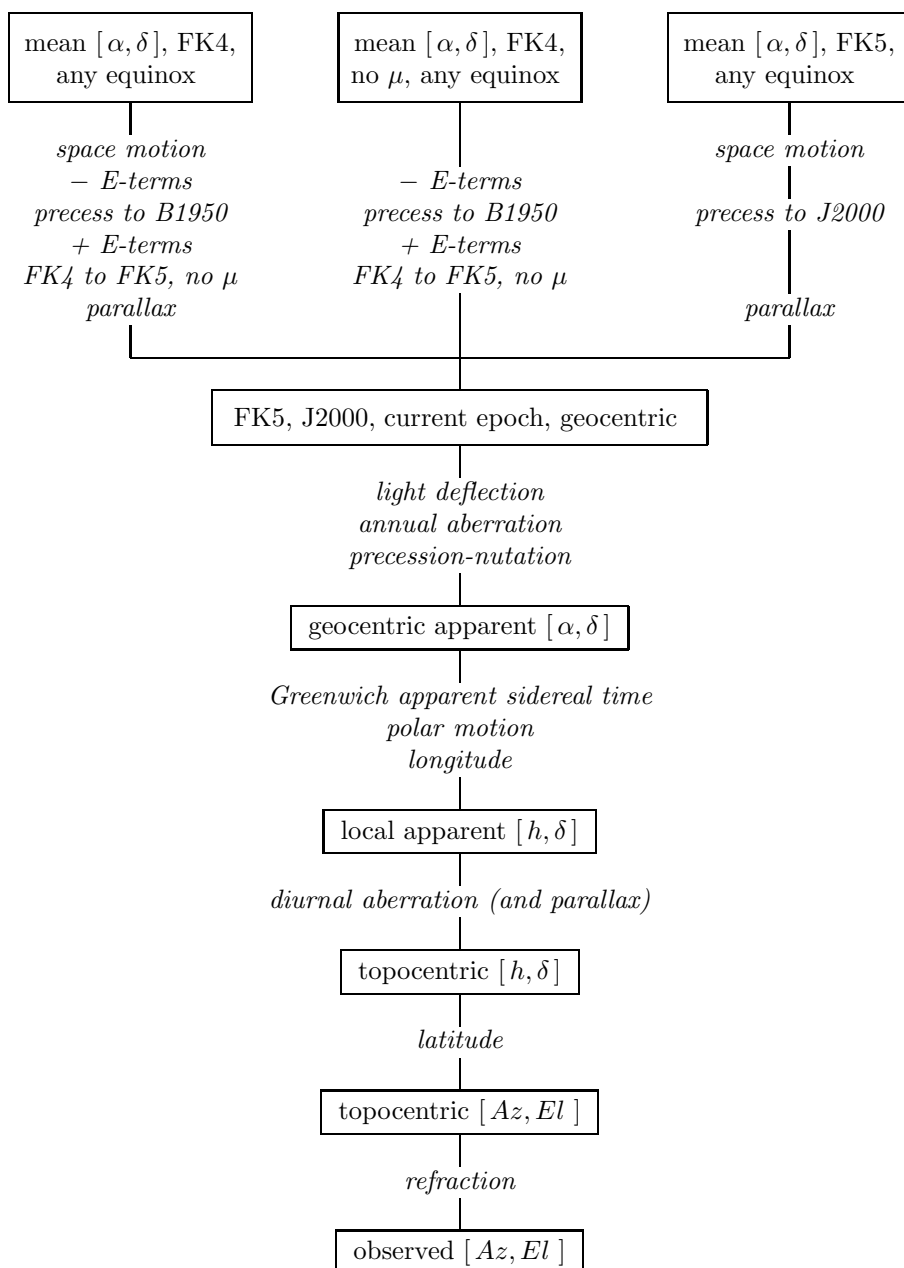

Figure 1: **Relationship between celestial coordinates, pre-ICRS**

Prior to the introduction of the International Celestial Reference System, star positions were published or cataloged using one of the mean $[\alpha, \delta]$ systems shown at the top, each with its own specific precession and aberration models. The “FK4” systems, not at present supported by SOFA, were used before 1984 and were usually equinox B1950. The “FK5” system, equinox J2000 (to which the ICRS is nominally aligned), then took over. The figure relates a star’s mean $[\alpha, \delta]$ to the actual line-of-sight to the star.

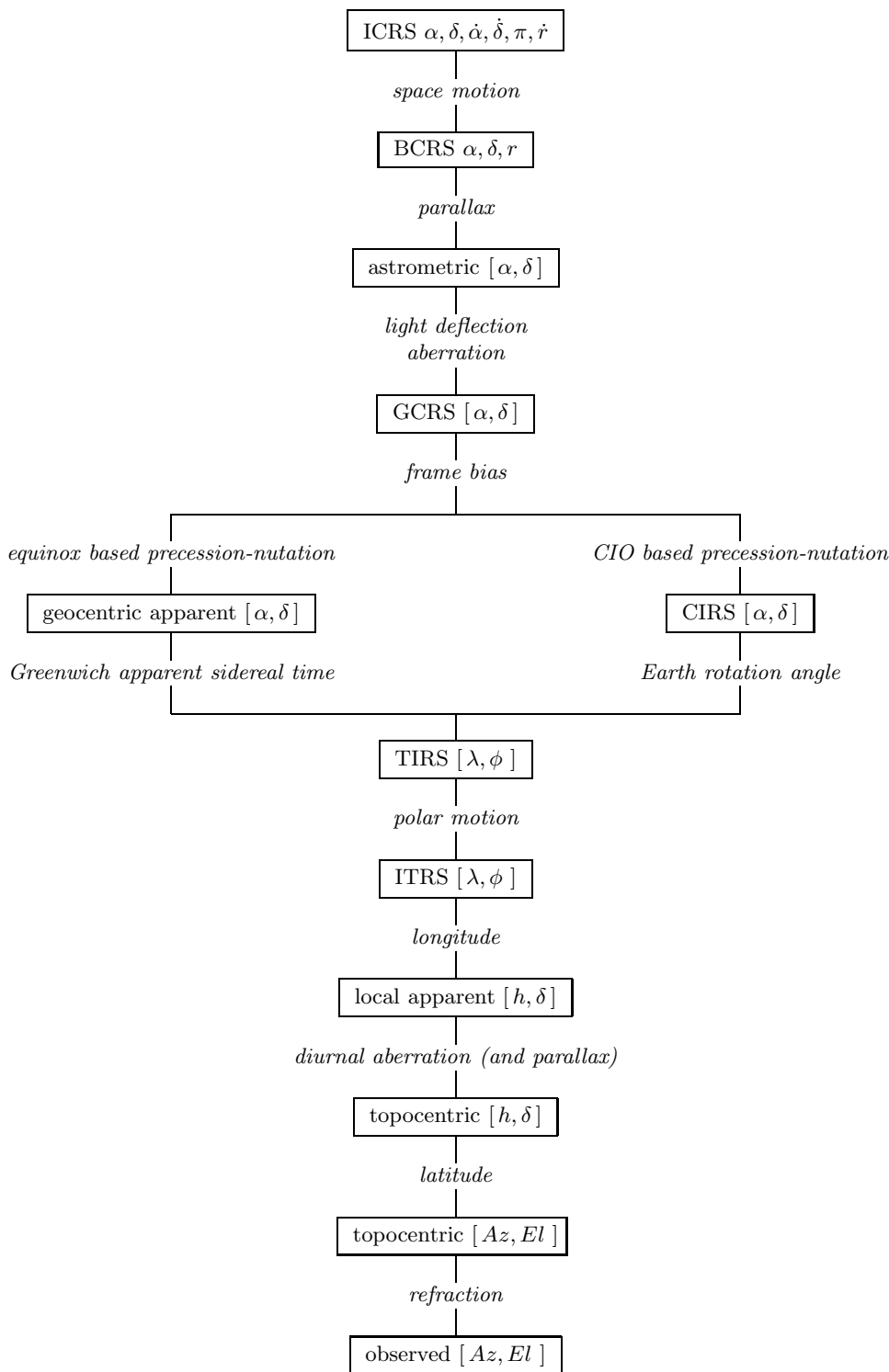

Figure 2: **Relationship between celestial coordinates, post-IAU-2000**

Since the introduction of the ICRS, the moving equator and ecliptic no longer provide the basis of high-precision astrometry, and mean places have fallen out of use. ICRS was nominally aligned to mean J2000, with a residual *frame bias* of about 23 mas that can be ignored for many applications. In addition, a new zero-point for right ascension of date, the CIO, has replaced the equinox, breaking the final link with the ecliptic as far as the user is concerned. The figure relates a star's ICRS $[\alpha, \delta]$ to the actual line-of-sight to the star. The right-hand branch shows the modern CIO/ERA method of reckoning the Earth rotation; the classical equinox/GST method, shown in the left-hand branch, remains an option for supporting older applications.

2. The ecliptic was retired as a reference plane for high-precision work. One difficulty had been a certain degree of confusion about exactly what “ecliptic” meant. Classically, the basis was the geometric path of the Sun as seen from the Earth-Moon barycenter, but it had become more usual instead to start from the EMB orbital angular momentum vector. It turns out these give the same result only if the orbital angular momentum vector is referred to the moving ecliptic itself; the angular momentum vector in inertial space leads to a slightly different plane, moving the equinox by about $0''.1$. Other difficulties with the ecliptic included exactly how to average out the orbital perturbations, uncertainty about whether the plane should go through the Sun or the solar-system barycenter, and so on.
3. Greenwich sidereal time (GST), which is a complicated function of both Earth rotation (UT1) and time (not quite the same thing), was replaced by *Earth rotation angle* (ERA), which is a straightforward linear transformation of UT1 alone and which represents the Earth’s rotation in inertial space.
4. The corollary of the change from GST to ERA is that the zero point of apparent right ascension has changed. The new α zero-point is called the *celestial intermediate origin* (CIO). The CIO, a *non-rotating origin*, is kinematically, not geometrically, defined, with the result that it is impossible to draw a diagram that explains where the CIO is on a given date. However, the concept is easy to grasp: the CIO is simply a point on the equator that moves as little as possible. It necessarily bobs north and south as the equator of date moves, but does not move along the equator; from moment to moment its motion is always at right-angles to the equator. For epoch 2000.0 the CIO was placed close to GCRS right ascension zero, and throughout the 20th and 21st centuries it remains within $0''.1$ of that alignment.

2.4 The IAU 2000 changes

The switch from equinox/GST to CIO/ERA, introduced by the IAU in 2000 in order to bring about a clean separation between Earth rotation and precession-nutation, will take some years to come into wide use. Although recent textbooks have embraced the ICRS, all but a handful pre-date the introduction of the CIO, making it difficult to teach the new methods – even though they are in many ways simpler, with less to go wrong. There is in any case little incentive now that astronomers no longer need to prepare apparent places for their observing runs, a chore left to the telescope control computer. Furthermore, the latest and most precise precession-nutation and Earth rotation theories can be presented using either framework, with equal accuracy and with hardly any difference in the total amount of computation required. Given these factors, and taking into account the large number of equinox/GST based applications that exist, the SOFA policy at present is to support both methods – with the strong recommendation that for all new applications the CIO based methods should be adopted.

2.5 Frame bias

The International Celestial Reference System was nominally oriented to match the J2000 dynamical frame. Subsequent observations located the J2000 mean pole at ICRS $[X, Y]$ coordinates

$[-0^{\circ}016617, -0^{\circ}0068192]^1$, with the J2000 mean equinox lying $0^{\circ}0146$ west of the ICRS meridian.

2.6 CIO and TIO

The celestial intermediate origin, CIO, is located using a quantity called $s(t)$, which is the difference between two right ascensions of the same point. The point is the ascending node of the (moving) CIP equator on the (fixed) GCRS equator; the two right ascensions are with respect to the GCRS and the CIP/CIO respectively. The quantity s is defined by an integral that depends on the path of the precessing-nutating CIP, but is normally estimated using a series. The series used in the SOFA routines `iau_S00` and `iau_S06` is in fact for $s + XY/2$, where X and Y are the CIP coordinates of date.

There is an analogous quantity s' that applies to terrestrial coordinates, depends on the history of polar motion, and locates the terrestrial intermediate origin, TIO. It is extremely small, under 0.1 mas even after two centuries. The SOFA routine `iau_SP00` implements a standard model.

2.7 Equation of the origins

The *equation of the origins* (EO) is a useful quantity that captures the essential difference between the old and the new systems. In applications that need to support both the old, equinox based, and new, CIO based, systems, it will usually be found best to base the application on CIO/ERA and to use the EO when dealing with sidereal time and equinox based right ascensions.

The expression for calculating hour angle is the same in either the old or new system:

$$h = \theta - \alpha,$$

where θ is now Earth rotation angle but was formerly Greenwich apparent sidereal time, and α is referred to the celestial intermediate origin but was formerly referred to the true equinox of date. The difference ERA–GST, or equivalently the distance from the equinox to the CIO, is called the “equation of the origins” (EO). The EO is dominated by the precession in right ascension, causing it to change by about $46''$ per year, but includes also the nutation in right ascension (otherwise known as the equation of the equinoxes) and a number of small correction terms.

2.8 Equinox versus CIO

Although in the classical picture precession-nutation is thought of as affecting both the equator and the equinox, the latter aspect is nothing more than a geometrical consequence of the chosen coordinate system. The essence of precession-nutation is that it is all about the motion of the

¹When components of a unit vector are quoted in angular measure this should be taken to mean the radian equivalent.

Earth’s pole (and hence the equator), and in the post-IAU-2000 CIO based approach it is both normal and sufficient to specify the instantaneous pole, which is called the *celestial intermediate pole* (CIP), simply as $[X, Y]$, the first two components of the CIP’s GCRS unit vector. Indeed, one attraction of the new method is that series for $X(t)$ and $Y(t)$ exist (see the SOFA routine `iau_XY06`) that deliver the CIP as a function of time in a particularly straightforward way.

Even so, the ecliptic is never far away. The tidal forces that cause precession-nutation are from bodies that remain near the ecliptic plane, and descriptions of these effects are at their most concise when expressed in ecliptic based coordinates. Hence even in the latest precession theories there is still an ecliptic, and the existing nutation series are with respect to the mean equator and ecliptic of date.

Moreover, the classical precession angles, when used to generate the 3×3 precession matrix, automatically deliver the equinox, whether it is wanted or not. It appears as the top row of the epoch-to-date precession-nutation matrix, which is the unit vector towards the equinox (just as the bottom row is the unit vector towards the pole; the middle row is simply the vector product $\text{pole} \times \text{equinox}$).

On the face of it, this makes direct use of the classical matrix attractive. Starting with existing precession and nutation models, it delivers traditional equinox based right ascensions without further ado, ready to be used in conjunction with sidereal time. However, there is a hidden danger. Any change in the precession or nutation models requires a corresponding change to the formulation of sidereal time, and it is the SOFA user’s responsibility to employ a matching set of precession, nutation and sidereal time models if hour angles are to be calculated reliably. For example, mixing old and new precession-nutation and sidereal time can introduce errors in h at the $0''.05$ level.

In the newer SOFA routines, multiple sidereal time formulations are avoided by working internally with respect to the CIO, which is nearly independent of the adopted precession-nutation model. The distance between the CIO and the chosen equinox is the *equation of the origins* (see Section 2.7). The EO can be calculated from any supplied precession-nutation matrix, and if subtracted from the Earth rotation angle automatically yields a Greenwich apparent sidereal time appropriate for use with that particular matrix.

2.9 The celestial to terrestrial transformation

Figure 2 shows how frame bias, precession-nutation, Earth rotation and polar motion form a chain of transformations connecting celestial coordinates (GCRS) to terrestrial coordinates (ITRS). Written out in matrix form, the chain is:

$$\mathbf{v}_{\text{ITRS}} = \mathbf{R}_{\text{PM}} \times \mathbf{R}_3(\theta) \times \mathbf{R}_{\text{NPB}} \times \mathbf{v}_{\text{GCRS}} \quad (1)$$

where:

- \mathbf{v}_{GCRS} and \mathbf{v}_{ITRS} are the same direction with respect to the two reference systems;

- the matrix \mathbf{R}_{NPB} represents the combined effects of frame bias and precession-nutation and defines the orientation of the celestial intermediate pole and a longitude origin;
- $\mathbf{R}_3(\theta)$ is Earth rotation, with θ either ERA or GST depending on whether \mathbf{R}_{NPB} is CIO based or equinox based; and
- the matrix \mathbf{R}_{PM} takes account of polar motion.

The sequence of coordinate systems in Eq. (1) is:

1. The Geocentric Celestial Reference System, which is effectively the same orientation as ICRS. The bias+precession+nutation transformation then produces...
2. ...either Celestial Intermediate Reference System coordinates, if the matrix \mathbf{R}_{NPB} was CIO based, or classical apparent place, if the matrix \mathbf{R}_{NPB} was equinox based. The rotation through either ERA or GST, as appropriate, then gives...
3. ...Terrestrial Intermediate Reference System coordinates, which after polar motion has been applied and the small adjustment onto the terrestrial intermediate origin (TIO) has been made gives...
4. ...International Terrestrial Reference System coordinates: where on the Earth the star appears to be in the (geographical) zenith, and easily transformed into $[h, \delta]$ for other locations.

3 SOFA EARTH ATTITUDE MODELS

3.1 Classical precession

For equinox based use, SOFA offers a choice of three models for the classical precession:

- The Fricke-Lieske, IAU 1976, “FK5” model. The conventional ζ , z and θ Euler angles are generated by the SOFA routine `iau_PREC76` and the precession matrix by `iau_PMAT76`.
- The IAU 2000 model. This is in the form of corrections, due to Mathews, Herring & Buffet, to the IAU 1976 model. The corrections can be obtained by calling `iau_PR00` (rates) and `iau_BI00` (position, i.e. frame bias). The complete precession matrix, including frame bias, is available from `iau_PMAT00`, while individual frame bias and precession matrices can be obtained with `iau_BP00`.
- The Capitaine et al. IAU 2006 model. The SOFA routine `iau_PFW06` produces the four Fukushima-Williams angles, $\bar{\gamma}$, $\bar{\phi}$, $\bar{\psi}$ and ϵ_A , that automatically include the frame bias. The precession+bias matrix is available from `iau_PMAT06`. Another advantage of the Fukushima-Williams parameterization is that the classical nutation angles $\Delta\psi$ and $\Delta\epsilon$ can be added directly to the final two angles, $\bar{\psi}$ and ϵ_A , if the desired end product is the complete nutation+precession+bias matrix.

Another aspect of precession is the obliquity of the ecliptic. There are two supported models:

- The IAU 1976 mean obliquity, which can be computed by calling `iau_OBL80`. This obliquity also forms the foundation for the IAU 2000A/B precession-nutation.
- The IAU 2006 mean obliquity, `iau_OBL06`.

3.2 Classical nutation

SOFA provides three nutation models:

- The IAU 1980 model: `iau_NUT80`.
- The IAU 2000A model: `iau_NUT00A`.
- The IAU 2000B model: `iau_NUT00B`.

All three return the classical components of nutation in longitude and obliquity, $\Delta\psi$, $\Delta\epsilon$, from which a nutation matrix can (if required) be generated by calling `iau_NUMAT`, and from which the *equation of the equinoxes* (EE), described later, can be found.

The IAU 2000B model is an abridged version of the full 1365-frequency IAU 2000A model. It is a fraction of the size (smaller even than the IAU 1980 model) and achieves 1 mas accuracy throughout 1995-2050.

The best nutation model that is currently available is IAU 2000A. When using this in conjunction with the latest (IAU 2006) precession model it is formally necessary to apply certain small adjustments to the nutation. This IAU-2006-compatible form of the IAU 2000A nutation is available from the routine `iau_NUT06A`. When using the IAU 2000B nutation these adjustments can be neglected.

If the application requires the nutation in the classical matrix form, it can be generated in a single call by using `iau_NUTM80`, `iau_NUM00A`, `iau_NUM00B` or `iau_NUM06A` for the IAU 1980, IAU 2000A, IAU 2000B or IAU 2006/2000A variants respectively.

3.3 The CIP X, Y

SOFA offers six routines for obtaining X, Y , the first two coordinates of the CIP unit vector:

- When the bias-precession-nutation matrix is already known, the CIP X, Y can be extracted by calling `iau_BPN2XY`.
- The IAU 2000A X, Y and additionally the CIO locator s can be obtained using `iau_XYS00A`.
- For the IAU 2000B model, X, Y and s can be obtained by calling `iau_XYS00B`.

- When the bias-precession-nutation is available in the form of Fukushima-Williams angles, the CIP coordinates can be computed with `iau_FW2XY`.
- In the case of the IAU 2006/2000A model, SOFA provides a routine `iau_XY06` that computes X and Y directly from series. This formulation is distinct from the other SOFA IAU 2006/2000A routines but agrees at the $1\ \mu\text{s}$ level.

3.4 The CIO locator, s

Although direct series for s exist, a more concise result is obtained if the quantity modeled is not s itself but $s + XY/2$, where X, Y are the CIP coordinates. SOFA provides three routines for s in the IAU 2000 system...

- The routine `iau_S00A` calculates s , first evaluating the IAU 2000A bias-precession-nutation to obtain the CIP coordinates X and Y .
- The routine `iau_S00B` does the same but using the IAU 2000B model.
- Where X and Y are already known, it is computationally more efficient to call the routine `iau_S00`.

... and two routines for s in the IAU 2006/2000A system:

- The routine `iau_S06A` calculates s , first evaluating the IAU 2006/2000A bias-precession-nutation to obtain the CIP coordinates X and Y .
- Where X and Y are already known (for example from `iau_XY06`), it is computationally more efficient to call the routine `iau_S06`.

3.5 Polar motion

The polar motion matrix, \mathbf{R}_{PM} in Eq. (1) depends on IERS tabulations of the pole coordinates $x_{\text{p}}, y_{\text{p}}$. The SOFA routine `iau_P0M00` uses these pole coordinates, together with the TIO locator s' to construct the \mathbf{R}_{PM} matrix. A conventional estimate of s' is provided by the routine `iau_SP00`. Prior to the introduction of the IAU 2000 procedures s' was neglected.

3.6 Earth rotation

In Eq. 1, the angle θ is either Greenwich apparent sidereal time (if \mathbf{R}_{NPB} is equinox based) or Earth rotation angle (if \mathbf{R}_{NPB} is CIO based). SOFA includes routines to calculate both.

Support for classical sidereal time accounts for a total of 14 SOFA routines. The large number is because:

- Sidereal time includes a precession-nutation component as well as the main Earth rotation component. Consequently, each new precession-nutation model requires its own matching sidereal time model.
- Sidereal time has several component parts. The ST that is θ in the expression:

$$h_{\text{Greenwich}} = \theta - \alpha_{\text{apparent}}$$

is *apparent* sidereal time and comprises:

$$\theta = \text{GMST} + \text{EE}$$

where EE is the *equation of the equinoxes*. The classical equation of the equinoxes is $\Delta\psi \cos \epsilon$, where $\Delta\psi$ is the nutation in longitude and ϵ is the obliquity, but from 1994 small periodic corrections called the *complementary terms* have been added.

SOFA provides three generations of IAU GMST models:

- `iau_GMST82` computes the IAU 1982 GMST, consistent with the IAU 1976 precession.
- `iau_GMST00` computes the GMST consistent with the precession part of IAU 2000A.
- `iau_GMST06` computes the GMST consistent with the IAU 2006 precession.

Five SOFA routines deliver the equation of the equinoxes:

- `iau_EQEQ94` computes the IAU 1994 EE.
- `iau_EE00A` computes the IAU 2000A EE.
- `iau_EE00B` computes the IAU 2000B EE.
- Where $\Delta\psi$ and ϵ are already available, `iau_EE00` can be called, producing the IAU 2000 EE.
- `iau_EE06A` computes the IAU 2006/2000A EE.

The SOFA routine `iau_EECT00` computes the value of the EE complementary terms for the IAU 2000 case. No corresponding IAU 2000/2000A routine exists; should the quantity be needed, it can be computed by subtracting $\Delta\psi \cos \epsilon$ from the EE, the latter obtained by calling `iau_EE06A`.

Finally, SOFA routines are provided for calculating five generations of Greenwich apparent sidereal time:

- `iau_GST94` computes the IAU 1994 GST.
- `iau_GST00A` computes the IAU 2000A GST.

- `iau_GST00B` computes the IAU 2000B GST.
- `iau_GST06` computes the GST starting from the NPB matrix. Although the routine uses the IAU 2006/2000A series for $s + XY/2$ (hence its “06” suffix), it is otherwise independent of the precession-nutation model and can in practice be used with any equinox-based NPB matrix.
- `iau_GST06A` computes the IAU 2006/2000A GST.

Working with respect to the CIO rather than the equinox sweeps away sidereal time’s complexities and opportunities for error. The Earth rotation angle, the CIO based counterpart of GST, is simply a conventional linear transformation of UT1, and only one SOFA routine is needed:

- `iau_ERA00`: Earth rotation angle.

3.7 Fundamental arguments

The models for nutation, the CIO locator s and the CIP X, Y are all functions of *fundamental arguments*, angles which themselves are functions of time. SOFA routines implement the IERS 2003 expressions for 14 such angles:

<code>iau_FAL03</code>	Delaunay variable l
<code>iau_FALP03</code>	Delaunay variable l'
<code>iau_FAF03</code>	Delaunay variable F
<code>iau_FAD03</code>	Delaunay variable D
<code>iau_FAOM03</code>	Delaunay variable Ω
<code>iau_FAME03</code>	mean longitude of Mercury
<code>iau_FAVE03</code>	mean longitude of Venus
<code>iau_FAE03</code>	mean longitude of Earth
<code>iau_FAMA03</code>	mean longitude of Mars
<code>iau_FAJU03</code>	mean longitude of Jupiter
<code>iau_FASA03</code>	mean longitude of Saturn
<code>iau_FAUR03</code>	mean longitude of Uranus
<code>iau_FANE03</code>	mean longitude of Neptune
<code>iau_FAPA03</code>	general accumulated precession in longitude

In a few cases the published models use slightly different expressions for one or two of the fundamental arguments, and where this occurs the SOFA routine uses the published expression rather than the standard version.

3.8 Supporting routines

The successive generations of precession-nutation models are supported by SOFA routines that generate the various matrices from a variety of starting points.

The IAU 1976/1980 models are used by `iau_PNM80`.

The IAU 2000A/B models are used by `iau_C2I00A`, `iau_C2I00B`, `iau_C2IBPN`, `iau_C2T00A`, `iau_C2T00B`, `iau_C2TPE`, `iau_C2TXY`, `iau_PN00`, `iau_PN00A`, `iau_PN00B`, `iau_PNM00A` and `iau_PNM00B`.

SOFA support for the current generation of models, based on the IAU 2006/2000A precession-nutation, is described in more detail in the next Section.

4 CURRENT MODELS

The latest models supported by SOFA are based on the IAU 2006 precession, the IERS 2003 polar motion and the IAU 2000 nutation and Earth rotation. With one exception (`iau_XY06`), all the SOFA routines rest upon a non-redundant set of models, guaranteeing self consistency: the same quantity computed via different sequences of SOFA calls should not vary apart from rounding errors.

4.1 Canonical basis

The models that form the *primary canonical basis* for the latest SOFA routines, supporting both CIO based and equinox based applications, are as follows:

- The IAU 2006 precession model, in the Fukushima-Williams four angle parameterization.
- The IAU 2000A nutation model.
- The IAU 2006 adjustments to the IAU 2000A nutation model.
- The IAU 2006 model for the quantity $s + XY/2$, which locates the celestial intermediate origin on the CIP equator.
- The IAU 2000 model for the quantity s' , which locates the terrestrial intermediate origin on the CIP equator.
- The IAU 2000 expression for ERA(UT1).
- A GMST model consistent with IAU 2006.

The derived products are:

- Precession-nutation matrices, for transforming between GCRS and apparent place (either CIO based or equinox based).
- CIP coordinates X, Y .
- Equation of the origins, $EO = ERA - GST$.

- Greenwich (apparent) sidereal time, GST.
- Equation of the equinoxes, $EE = GST - GMST$.

An alternative canonical basis for the CIO based products is:

- Direct series for the IAU 2006/2000A CIP X, Y .
- The IAU 2006/2000A model for $s + XY/2$.
- The IAU 2000 model for s' .
- The IAU 2000 expression for ERA(UT1).

To support equinox based applications the following additional models are required:

- The first two Fukushima-Williams angles, namely $\bar{\gamma}$ and $\bar{\phi}$.
- A GMST model consistent with IAU 2006.

The angles based and series based approaches agree to of order $1 \mu\text{as}$; anyone attempting to mix the two techniques in a single application should not be surprised when discrepancies of this size appear. See Wallace, P.T. & Capitaine, N., *Precession-nutation procedures consistent with IAU 2006 resolutions*, *Astronomy & Astrophysics*, **459**, 981-985, 2006 for further details of the two methods.

4.2 SOFA routines

With the exception of `iau_XY06`, which computes CIP X, Y directly by series, and `iau_P06E`, which calculates all the equinox based IAU 2006 precession angles, all of the SOFA routines whose names contain “06” stem from the primary canonical basis set out at the start of Section 4. Hence the remainder of the present Section applies to the primary canonical basis rather than the alternative X, Y series starting point. Also, with the partial exception of the low-level routines `iau_PN06`, `iau_PN06A` and `iau_BP06`, which keep frame bias and precession separate, everything refers to the GCRS pole rather than the dynamical pole.

For any given date, the complete matrix \mathbf{R}_{NPB} in Eq. (1) can be obtained by calling the function `iau_C2I06A`, for the CIO based version, or `iau_PNM06A`, for the equinox based version.

At a lower level, the function `iau_PFW06` returns the Fukushima-Williams precession angles themselves (with frame bias included), while `iau_NUT06A` obtains the nutation components. Once these nutation components have been added to the appropriate two precession angles, the equinox based \mathbf{R}_{NPB} matrix can be generated by calling `iau_FW2M`. Alternatively, the CIP X, Y coordinates can be obtained by calling `iau_FW2XY`, the CIO locator s computed using the function `iau_S06A`, and the CIO based \mathbf{R}_{NPB} matrix formed using `iau_C2IXYS`. This latter route provides an opportunity to introduce corrections to X, Y , as published by the IERS. The

resulting matrix transforms from GCRS to CIRS; its transpose, available by calling `iau_TR`, performs the inverse transformation, i.e. CIRS to GCRS.

To support older applications that use the Euler angles ζ, z, θ to construct the precession matrix, the routine `iau_PB06` is provided. The starting point is the Fukushima-Williams angles, so that the ζ, z, θ returned by `iau_PB06` are consistent with the primary canonical basis, and include frame bias.

Earth rotation angle, from which $R_3(\theta)$ in the CIO based form of Expression (1) can be applied, is available using `iau_ERA00`, which is a function of UT1 alone. Or, for the case where the equinox based form of Expression (1) is being used, the requisite Greenwich apparent sidereal time can be obtained by calling `iau_GST06A`, a function of time (*i.e.* TT) as well as UT1.

A rotation matrix that performs the complete celestial to terrestrial transformation (i.e. GCRS to ITRS), given the TT, UT1 and polar motion, can be obtained by calling `iau_C2T06A`. Low-level routines `iau_C2TCIO` and `iau_C2TEQX` (which are in fact identical in form) construct the GCRS to ITRS matrix given an appropriate NPB matrix, a polar motion matrix, and the ERA or GST.

A key component of the GST calculation is the equation of the origins, which can be obtained as a function of time by calling `iau_E006A`. Alternatively, to obtain the EO corresponding to an independently calculated \mathbf{R}_{NPB} matrix and CIO locator, `iau_EORS` can be called. As well as its role in computing GST, the EO is useful when CIRS right ascension is to be computed from apparent right ascension or *vice versa*. Should the application require GMST or EE, the former can be computed by calling `iau_GMST06` and the latter by subtracting GMST from GST.

Section 5.5 demonstrates how to generate the CIO based celestial to terrestrial transformation with the usual angles based method. Section 5.6 does the same but starting from the X, Y series. In both cases IERS CIP corrections and Earth orientation parameters are taken into account.

5 EXAMPLES

Sections 5.1–5.6, below, present a complete Fortran program that computes the GCRS-to-ITRS transformation matrix and various intermediate products, using a number of different approaches and generations of SOFA routines. The code is interspersed with explanatory text and numerical results, but is otherwise compilable as it stands.

Five methods are demonstrated:

5.2 IAU 1976/1980/1982/1994 (equinox based)

5.3 IAU 2000A, CIO based, using classical angles

5.4 IAU 2000A, equinox based, using classical angles

5.5 IAU 2006/2000A, CIO based, using classical angles

5.6 IAU 2006/2000A, CIO based, using X, Y series

The starting point is as follows:

date & time	2007 April 05, 12 ^h 00 ^m 00 ^s 0 UTC
x_p	+0".0349282
y_p	+0".4833163
UT1–UTC	–0 ^s .072073685
$d\psi_{1980}$	–0".0550655
$d\epsilon_{1980}$	–0".0063580
dX_{2000}	+0".0001725
dY_{2000}	–0".0002650
dX_{2006}	+0".0001750
dY_{2006}	–0".0002259

The Earth orientation parameters are close to those published by the IERS for the specified date and time. They are corrections to the standard Earth models and come from observation: the polar motion quantities x_p and y_p correct the terrestrial pole, UT1–UTC is the time correction that defines the Earth rotation, and dX_{2000} and dY_{2000} are corrections to the celestial pole with respect to the IAU 2000A model.

The quantities dX_{2006} and dY_{2006} are adjusted versions of dX_{2000} and dY_{2000} that for the purposes of this demonstration correct the celestial pole with respect to the IAU 2006/2000A model.

5.1 Preliminaries

The Fortran program begins as follows:

```

* SOFA examples

      IMPLICIT NONE

* Arcseconds to radians
      DOUBLE PRECISION AS2R
      PARAMETER ( AS2R = 4.848136811095359935899141D-6 )

* 2Pi
      DOUBLE PRECISION D2PI
      PARAMETER ( D2PI = 6.283185307179586476925287D0 )

      INTEGER IY, IM, ID, IH, MIN, J
      DOUBLE PRECISION SEC, XP, YP, DUT1,
:           DDP80, DDE80, DX00, DY00, DX06, DY06,
:           DJMJDO, DATE, TIME, UTC, DAT,
:           TAI, TT, TUT, UT1, RP(3,3), DP80, DE80,
:           DPSI, DEPS, EPSA, RN(3,3), RNPB(3,3),
:           EE, GST, RC2TI(3,3), RPOM(3,3),

```

```

:           RC2IT(3,3), X, Y, S,
:           RC2I(3,3), ERA, DPO0, DE00, RB(3,3),
:           RPB(3,3), V1(3), V2(3), DDP00, DDE00
DOUBLE PRECISION iau_OBL80, iau_EQEQ94, iau_ANP, iau_GMST82,
:           iau_ERA00, iau_SP00, iau_EE00, iau_GMST00,
:           iau_S06

* UTC.
  IY = 2007
  IM = 4
  ID = 5
  IH = 12
  MIN = 0
  SEC = 0D0

* Polar motion (arcsec->radians).
  XP = 0.0349282D0 * AS2R
  YP = 0.4833163D0 * AS2R

* UT1-UTC (s).
  DUT1 = -0.072073685D0

* Nutation corrections wrt IAU 1976/1980 (mas->radians).
  DDP80 = -55.0655D0 * AS2R/1000D0
  DDE80 = -6.3580D0 * AS2R/1000D0

* CIP offsets wrt IAU 2000A (mas->radians).
  DX00 = 0.1725D0 * AS2R/1000D0
  DY00 = -0.2650D0 * AS2R/1000D0

* CIP offsets wrt IAU 2006/2000A (mas->radians).
  DX06 = 0.1750D0 * AS2R/1000D0
  DY06 = -0.2259D0 * AS2R/1000D0

* TT (MJD).
  CALL iau_CAL2JD ( IY, IM, ID, DJMJDO, DATE, J )
  TIME = ( 60D0*(60D0*DBLE(IH) + DBLE(MIN)) + SEC ) / 86400D0
  UTC = DATE + TIME
  CALL iau_DAT ( IY, IM, ID, TIME, DAT, J )
  TAI = UTC + DAT/86400D0
  TT = TAI + 32.184D0/86400D0

* UT1.
  TUT = TIME + DUT1/86400D0
  UT1 = DATE + TUT

```

The resulting TT and UT1 are as follows:

$$\begin{aligned} \text{TT} &= 2400000.5 + 54195.5007544444444444 \\ \text{UT1} &= 2400000.5 + 54195.499999165813831 \end{aligned}$$

n.b. Here and elsewhere the numerical results are given to an unrealistic precision, for comparison purposes.

5.2 IAU 1976/1980/1982/1994, equinox based

The next part of the Fortran code demonstrates the procedures that were used prior to the introduction (at the beginning of 2003) of the methods specified in the IAU 2000 resolutions.

```

* =====
* IAU 1976/1980
* =====

* IAU 1976 precession matrix, J2000 to date.
  CALL iau_PMAT76 ( DJMJD0, TT, RP )

* IAU 1980 nutation.
  CALL iau_NUT80 ( DJMJD0, TT, DP80, DE80 )

* Add adjustments: frame bias, precession-rates, geophysical.
  DPSI = DP80 + DDP80
  DEPS = DE80 + DDE80

* Mean obliquity.
  EPSA = iau_OBL80 ( DJMJD0, TT )

* Build the rotation matrix.
  CALL iau_NUMAT ( EPSA, DPSI, DEPS, RN )

* Combine the matrices: PN = N x P.
  CALL iau_RXR ( RN, RP, RNPB )

* Equation of the equinoxes, including nutation correction.
  EE = iau_EQEQ94 ( DJMJD0, TT ) + DDP80 * COS ( EPSA )

* Greenwich apparent sidereal time (IAU 1982/1994).
  GST = iau_ANP ( iau_GMST82 ( DJMJD0+DATE, TUT ) + EE )

* Form celestial-terrestrial matrix (no polar motion yet).
  CALL iau_CR ( RNPB, RC2TI )

```



```

CALL iau_RZ ( GST, RC2TI )

* Polar motion matrix (TIRS->ITRS, IERS 1996).
CALL iau_IR ( RPOM )
CALL iau_RX ( -YP, RPOM )
CALL iau_RY ( -XP, RPOM )

* Form celestial-terrestrial matrix (including polar motion).
CALL iau_RXR ( RPOM, RC2TI, RC2IT )

```

The results are as follows:

NPB matrix, equinox based

$$\begin{pmatrix} +0.999998403176203 & -0.001639032970562 & -0.000712190961847 \\ +0.001639000942243 & +0.999998655799521 & -0.000045552846624 \\ +0.000712264667137 & +0.000044385492226 & +0.999999745354454 \end{pmatrix}$$

$$\begin{aligned} \text{GST} &= 13^{\circ}412402380740 \\ &= 00^{\text{h}}53^{\text{m}}38^{\text{s}}976571378 \end{aligned}$$

celestial to terrestrial matrix (no polar motion)

$$\begin{pmatrix} +0.973104317592265 & +0.230363826166883 & -0.000703332813776 \\ -0.230363798723533 & +0.973104570754697 & +0.000120888299841 \\ +0.000712264667137 & +0.000044385492226 & +0.999999745354454 \end{pmatrix}$$

celestial to terrestrial matrix

$$\begin{pmatrix} +0.973104317712772 & +0.230363826174782 & -0.000703163477127 \\ -0.230363800391868 & +0.973104570648022 & +0.000118545116892 \\ +0.000711560100206 & +0.000046626645796 & +0.999999745754058 \end{pmatrix}$$

5.3 IAU 2000A, CIO based, using classical angles

At the start of 2003, the IAU 2000A precession-nutation model came into use. The following code uses classical precession and nutation angles to obtain the CIP coordinates X, Y , then uses the CIO locator s and the Earth rotation angle.

```

* =====
* IAU 2000A, CIO based
* =====

```

```

* CIP and CIO, IAU 2000A.
  CALL iau_XYS00A ( DJMJD0, TT, X, Y, S )

* Add CIP corrections.
  X = X + DX00
  Y = Y + DY00

* GCRS to CIRS matrix.
  CALL iau_C2IXYS ( X, Y, S, RC2I )

* Earth rotation angle.
  ERA = iau_ERA00 ( DJMJD0+DATE, TUT )

* Form celestial-terrestrial matrix (no polar motion yet).
  CALL iau_CR ( RC2I, RC2TI )
  CALL iau_RZ ( ERA, RC2TI )

* Polar motion matrix (TIRS->ITRS, IERS 2003).
  CALL iau_POM00 ( XP, YP, iau_SP00(DJMJD0,TT), RPOM )

* Form celestial-terrestrial matrix (including polar motion).
  CALL iau_RXR ( RPOM, RC2TI, RC2IT )

```

The results are as follows:

```

X   = +0.000712264729708
Y   = +0.000044385250265
s   = -0o.002200496

```

NPB matrix, CIO based

$$\begin{pmatrix} +0.999999746339445 & -0.000000005138721 & -0.000712264730182 \\ -0.000000026475329 & +0.99999999014975 & -0.000044385242666 \\ +0.000712264729708 & +0.000044385250265 & +0.999999745354420 \end{pmatrix}$$

```

ERA = 13o318492966097
     = 00h 53m 16s.438311863

```

celestial to terrestrial matrix (no polar motion)

$$\begin{pmatrix} +0.973104317573104 & +0.230363826247808 & -0.000703332818915 \\ -0.230363798804281 & +0.973104570735550 & +0.000120888549767 \\ +0.000712264729708 & +0.000044385250265 & +0.999999745354420 \end{pmatrix}$$

celestial to terrestrial matrix

$$\begin{pmatrix} +0.973104317697512 & +0.230363826239227 & -0.000703163482268 \\ -0.230363800456136 & +0.973104570632777 & +0.000118545366806 \\ +0.000711560162777 & +0.000046626403835 & +0.999999745754024 \end{pmatrix}$$

The rotational difference between the final matrices of this and the previous method is $53.29 \mu\text{as}$.

5.4 IAU 2000A, equinox based, using classical angles

Equinox based applications could instead do the following. In this case the nutation corrections ($d\psi, d\epsilon$) must be obtained by appropriately transforming the CIP corrections (dX, dY). It is necessary to select the GMST and EE routines that match the IAU 2000A precession, in this case `iau_GMST00` and `iau_EE00`.

```

* =====
* IAU 2000A, equinox based
* =====

* Nutation, IAU 2000A.
  CALL iau_NUTOOA ( DJMJD0, TT, DPO0, DE00 )

* Precession-nutation quantities, IAU 2000.
  CALL iau_PN00 ( DJMJD0, TT, DPO0, DE00,
:               EPSA, RB, RP, RPB, RN, RNPB )

* Transform dX,dY corrections from GCRS to mean of date.
  V1(1) = DX00
  V1(2) = DY00
  V1(3) = ODO
  CALL iau_RXP ( RNPB, V1, V2 )
  DDP00 = V2(1) / SIN ( EPSA )
  DDE00 = V2(2)

* Corrected nutation.
  DPSI = DPO0 + DDP00
  DEPS = DE00 + DDE00

* Build the rotation matrix.
  CALL iau_NUMAT ( EPSA, DPSI, DEPS, RN )

* Combine the matrices: PN = N x P.
  CALL iau_RXR ( RN, RPB, RNPB )

* Greenwich apparent sidereal time (IAU 1982/1994).
  GST = iau_ANP ( iau_GMST00 ( DJMJD0+DATE, TUT, DJMJD0, TT )
:               + iau_EE00 ( DJMJD0, TT, EPSA, DPSI ) )

```

```

* Form celestial-terrestrial matrix (no polar motion yet).
  CALL iau_CR ( RNPB, RC2TI )
  CALL iau_RZ ( GST, RC2TI )

* Polar motion matrix (TIRS->ITRS, IERS 2003).
  CALL iau_POM00 ( XP, YP, iau_SP00(DJMJD0,TT), RPOM )

* Form celestial-terrestrial matrix (including polar motion).
  CALL iau_RXR ( RPOM, RC2TI, RC2IT )

```

The results are as follows:

NPB matrix, equinox based

$$\begin{pmatrix} +0.999998402755640 & -0.001639289519579 & -0.000712191013215 \\ +0.001639257491365 & +0.999998655379006 & -0.000045552787478 \\ +0.000712264729795 & +0.000044385250265 & +0.999999745354420 \end{pmatrix}$$

$$\begin{aligned} \text{GST} &= 13^{\circ}412417084674 \\ &= 00^{\text{h}} 53^{\text{m}} 38^{\text{s}}980100322 \end{aligned}$$

celestial to terrestrial matrix (no polar motion)

$$\begin{pmatrix} +0.973104317573209 & +0.230363826247361 & -0.000703332818999 \\ -0.230363798803834 & +0.973104570735656 & +0.000120888549787 \\ +0.000712264729795 & +0.000044385250265 & +0.999999745354420 \end{pmatrix}$$

celestial to terrestrial matrix

$$\begin{pmatrix} +0.973104317697618 & +0.230363826238780 & -0.000703163482352 \\ -0.230363800455689 & +0.973104570632883 & +0.000118545366826 \\ +0.000711560162864 & +0.000046626403835 & +0.999999745754024 \end{pmatrix}$$

The rotational difference between the final matrices of this and the previous method (5.3) is $0.10 \mu\text{as}$.

5.5 IAU 2006/2000A, CIO based, using classical angles

From the beginning of 2009 the IAU 2006 precession will be used. The procedure based on classical precession and nutation angles is essentially the same as before (see Section 5.3), the only change being to call `iau_XYS06A` instead of `iau_XYS00A`.

```

* =====
* IAU 2006/2000A, CIO based
* =====

* CIP and CIO, IAU 2006/2000A.
  CALL iau_XYS06A ( DJMJD0, TT, X, Y, S )

* Add CIP corrections.
  X = X + DX06
  Y = Y + DY06

* GCRS to CIRS matrix.
  CALL iau_C2IXYS ( X, Y, S, RC2I )

* Earth rotation angle.
  ERA = iau_ERA00 ( DJMJD0+DATE, TUT )

* Form celestial-terrestrial matrix (no polar motion yet).
  CALL iau_CR ( RC2I, RC2TI )
  CALL iau_RZ ( ERA, RC2TI )

* Polar motion matrix (TIRS->ITRS, IERS 2003).
  CALL iau_POM00 ( XP, YP, iau_SP00(DJMJD0,TT), RPOM )

* Form celestial-terrestrial matrix (including polar motion).
  CALL iau_RXR ( RPOM, RC2TI, RC2IT )

```

The results are as follows:

```

X   = +0.000712264729599
Y   = +0.000044385250426
s   = -0o.002200475

```

NPB matrix, CIO based

$$\begin{pmatrix} +0.999999746339445 & -0.000000005138822 & -0.000712264730072 \\ -0.000000026475227 & +0.99999999014975 & -0.000044385242827 \\ +0.000712264729599 & +0.000044385250426 & +0.999999745354420 \end{pmatrix}$$

```

ERA = 13o318492966097
     = 00h 53m 16s.438311863

```

celestial to terrestrial matrix (no polar motion)

$$\begin{pmatrix} +0.973104317573127 & +0.230363826247709 & -0.000703332818845 \\ -0.230363798804182 & +0.973104570735574 & +0.000120888549586 \\ +0.000712264729599 & +0.000044385250426 & +0.999999745354420 \end{pmatrix}$$

celestial to terrestrial matrix

$$\begin{pmatrix} +0.973104317697535 & +0.230363826239128 & -0.000703163482198 \\ -0.230363800456037 & +0.973104570632801 & +0.000118545366625 \\ +0.000711560162668 & +0.000046626403995 & +0.999999745754024 \end{pmatrix}$$

The rotational difference between the final matrices of this and method (5.3) is $0.05 \mu\text{s}$.

5.6 IAU 2006/2000A, CIO based, using X,Y series

SOFA also provides an alternative formulation for the IAU 2006/2000A CIP, using series:

```

* =====
* IAU 2006/2000A, CIO based, using X,Y series
* =====

* CIP and CIO, IAU 2006/2000A.
  CALL iau_XY06 ( DJMJD0, TT, X, Y )
  S = iau_S06 ( DJMJD0, TT, X, Y )

* Add CIP corrections.
  X = X + DX06
  Y = Y + DY06

* GCRS to CIRS matrix.
  CALL iau_C2IXYS ( X, Y, S, RC2I )

* Earth rotation angle.
  ERA = iau_ERA00 ( DJMJD0+DATE, TUT )

* Form celestial-terrestrial matrix (no polar motion yet).
  CALL iau_CR ( RC2I, RC2TI )
  CALL iau_RZ ( ERA, RC2TI )

* Polar motion matrix (TIRS->ITRS, IERS 2003).
  CALL iau_POM00 ( XP, YP, iau_SP00(DJMJD0,TT), RPOM )

* Form celestial-terrestrial matrix (including polar motion).
  CALL iau_RXR ( RPOM, RC2TI, RC2IT )

END

```

The results are as follows:

$$\begin{aligned} X &= +0.000712264729525 \\ Y &= +0.000044385248875 \\ s &= -0''.002200475 \end{aligned}$$

NPB matrix, CIO based

$$\begin{pmatrix} +0.999999746339445 & -0.000000005138822 & -0.000712264729999 \\ -0.000000026475226 & +0.99999999014975 & -0.000044385241276 \\ +0.000712264729525 & +0.000044385248875 & +0.999999745354420 \end{pmatrix}$$

$$\begin{aligned} \text{ERA} &= 13^{\circ}318492966097 \\ &= 00^{\text{h}} 53^{\text{m}} 16^{\text{s}}438311863 \end{aligned}$$

celestial to terrestrial matrix (no polar motion)

$$\begin{pmatrix} +0.973104317573127 & +0.230363826247709 & -0.000703332818416 \\ -0.230363798804181 & +0.973104570735574 & +0.000120888551078 \\ +0.000712264729525 & +0.000044385248875 & +0.999999745354420 \end{pmatrix}$$

celestial to terrestrial matrix

$$\begin{pmatrix} +0.973104317697536 & +0.230363826239128 & -0.000703163481769 \\ -0.230363800456036 & +0.973104570632801 & +0.000118545368117 \\ +0.000711560162594 & +0.000046626402444 & +0.999999745754024 \end{pmatrix}$$

The rotational difference between the final matrices of this and method (5.3) is $0.29 \mu\text{as}$.

6 FURTHER READING

For numerical examples, with explanatory material, see *The Astronomical Almanac* and similar national publications. An extensive glossary is available as part of *The Astronomical Almanac Online*: see <http://asa.usno.navy.mil/SecM/Glossary.html>.

Detailed information on models and procedures can be found in:

- *Precession-nutation procedures consistent with IAU 2006 resolutions*, P. T. Wallace & N. Capitaine, *Astronomy & Astrophysics*, 459, 981-985 (2006)
- *High precision methods for locating the celestial intermediate pole and origin*, N. Capitaine & P. T. Wallace, *Astronomy & Astrophysics*, 450, 855-872 (2006)

- *Report of the International Astronomical Union Division I Working Group on Precession and the Ecliptic*, J.L. Hilton, N. Capitaine, J. Chapront, et al. *Celestial Mechanics & Dynamical Astronomy*, 94, 3, 351-367 (2006)
- *The IAU Resolutions on Astronomical Reference Systems, Time Scales, and Earth Rotation Models: Explanation and Implementation*, G.H. Kaplan, U.S. Naval Observatory Circular 179 (2005)
http://aa.usno.navy.mil/publications/docs/Circular_179.html
- *IERS Conventions (2003)*, D. D. McCarthy & G. Petit (eds.), Verlag des Bundesamts für Kartographie und Geodäsie, Frankfurt am Main (2004)
- *Expressions for IAU 2000 precession quantities*, N. Capitaine, P. T. Wallace & J. Chapront, *Astronomy & Astrophysics*, 412, 567-586 (2003)
- *A new precession formula*, T. Fukushima, *Astronomical Journal*, 126, 1, 494-534 (2003)
- *An abridged model of the precession-nutation of the celestial pole*, D. D. McCarthy & B. J. Luzum, *Celestial Mechanics & Dynamical Astronomy*, 85, 1, 37-49 (2003)
- *Modeling of nutation and precession: new nutation series for non-rigid Earth and insights into the Earth's interior*, P. M. Mathews, T. A. Herring & B. A. Buffet, *Journal of Geophysical Research*, 107, B4, ETG 3:1-26 (2002)
- *Application of the new concepts and definitions (ICRS, CIP and CEO) in fundamental astronomy*, P. K. Seidelmann & J. Kovalevsky, *Astronomy & Astrophysics*, 392, 341-351 (2002)
- *Definition of the Celestial Ephemeris Origin and of UT1 in the International Celestial Reference Frame*, N. Capitaine, B. Guinot & D. D. McCarthy, *Astronomy & Astrophysics*, 355, 398-405 (2000)
- *The celestial pole coordinates*, N. Capitaine, *Celestial Mechanics & Dynamical Astronomy*, 48, 2, 127-143 (1990)
- *1980 IAU theory of nutation – the final report of the IAU Working Group on Nutation*, P. K. Seidelmann, *Celestial Mechanics*, 27, 79-106 (1982)
- *The new definition of Universal Time*, S. Aoki, B. Guinot, G. H. Kaplan, et al., *Astronomy & Astrophysics*, 105, 359-361 (1982)
- *Expressions for the precession quantities based upon the IAU (1976) system of astronomical constants*, J. H. Lieske, T. Lederle, W. Fricke & B. Morando, *Astronomy & Astrophysics*, 58, 1, 1-16 (1977)

The following may also be useful for background reading:

- *Explanatory Supplement to the Astronomical Almanac*, ed. P. Kenneth Seidelmann (1992), University Science Books
- *Vectorial Astrometry*, C. A. Murray (1983), Adam Hilger

- *Spherical Astronomy*, Robin M. Green (1985), Cambridge University Press
- *Spacecraft Attitude Determination and Control*, ed. James R. Wertz (1986), Reidel
- *Fundamentals of Astrometry*, J. Kovalevsky & P. K. Seidelmann, Cambridge University Press

APPENDIX

Interrelationships between IAU 2006/2000A SOFA routines

The three diagrams set out SOFA's IAU 2006/2000A routines and the principal routines that each calls; a few frequently-used utility routines, such as FW2M and BPN2XY, are omitted in most cases in order to avoid over-complicating the diagram.

The first line of each box gives the name of the FORTRAN procedure, omitting the `iau_` prefix. Those routines classed as "canonical" have their names printed in red. Functions (as opposed to subroutines) are indicated by an equals sign at the start of the third line, preceding the value being returned. The second line lists the input (given) arguments (green), where all dates are given as either TT or UT (i.e. UT1); however, all routines use two argument Julian dates and fraction, either TT or UT1, as indicated. The third and following lines list the output (returned) arguments. All angular quantities are expressed in radians. Usual mathematical symbols have been used to denote the quantities, with matrices given in bold.

Line Comment

1. Routine name, **red** implies canonical routine.
2. Input arguments **green**, separated by commas. Note; all TT and UT (i.e. UT1) arguments occupy two FORTRAN arguments.
3. Output arguments, separated by commas. In the case of functions, the value returned is preceded by an equals (=) sign.

Quantities Returned by Canonical Routines

1. Precession angles γ , φ , ψ , which include frame bias.
2. Bias, precession, and bias-precession matrices, **B**, **P**, **PB**.
3. Mean obliquity of date, ε_A .
4. Nutation in longitude and obliquity $\Delta\psi$, $\Delta\varepsilon$.
5. Earth rotation angle θ .
6. Greenwich mean sidereal time GMST.
7. Locators of the CIO (s) and TIO (s').
8. Series evaluations for X and Y of the CIP.
9. Fundamental arguments, l , l' , F , D , Ω , λ_{Me} , λ_V , λ_E , λ_{Ma} , λ_{Ju} , λ_{Sa} , λ_{Ur} , λ_{Ne} , and p_A from IERS Conventions 2003. None of these routines appear in the charts.
10. Equinox based precession angles; ε_0 , ψ_A , ω_A , P_A , Q_A , π_A , II_A , χ_A , z_A , ζ_A , θ_A , p_A , η , φ , ψ . Angles are relative to the J2000 dynamical system and thus are without frame bias.

Other Quantities Returned

11. X , Y of CIP calculated using bias, precession and nutation angles, the chosen method that all the SOFA routines, with the sole exception of XY06.
12. Nutation matrix **N**.
13. GCRS to equinox and equator of date; bias, precession and nutation matrix **NPB**.
14. GCRS to Celestial Intermediate Reference System: matrix **C**.
15. Polar motion matrix, including s' **W**.
16. GCRS to ITRS matrix **Q**⁻¹.
17. Greenwich apparent sidereal time, GAST.
18. Equation of the equinoxes **EE**.
19. Equation of the origins **EO**.
20. Equinox precession angles ζ_B , z_B , θ_B including frame bias.

IAU 2006/2000A SOFA ROUTINES

Chart 1: The main routines for transforming from the GCRS to CIRS, TIRS and ITRS.

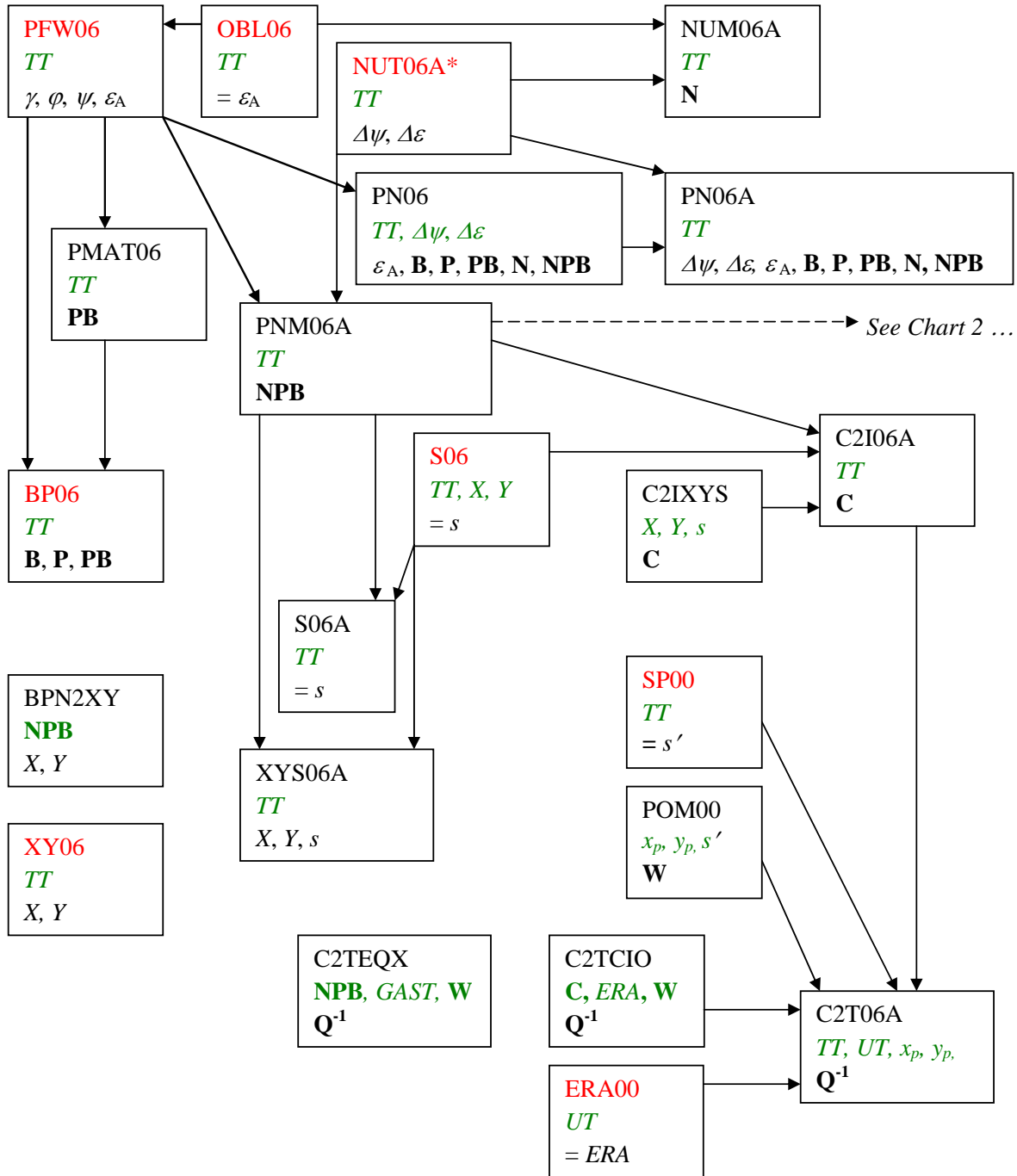

* Note: **NUT06A** calls **NUT00A**.

IAU 2006/2000A SOFA ROUTINES

Chart 2: Equinox based routines for calculating GAST and related quantities.

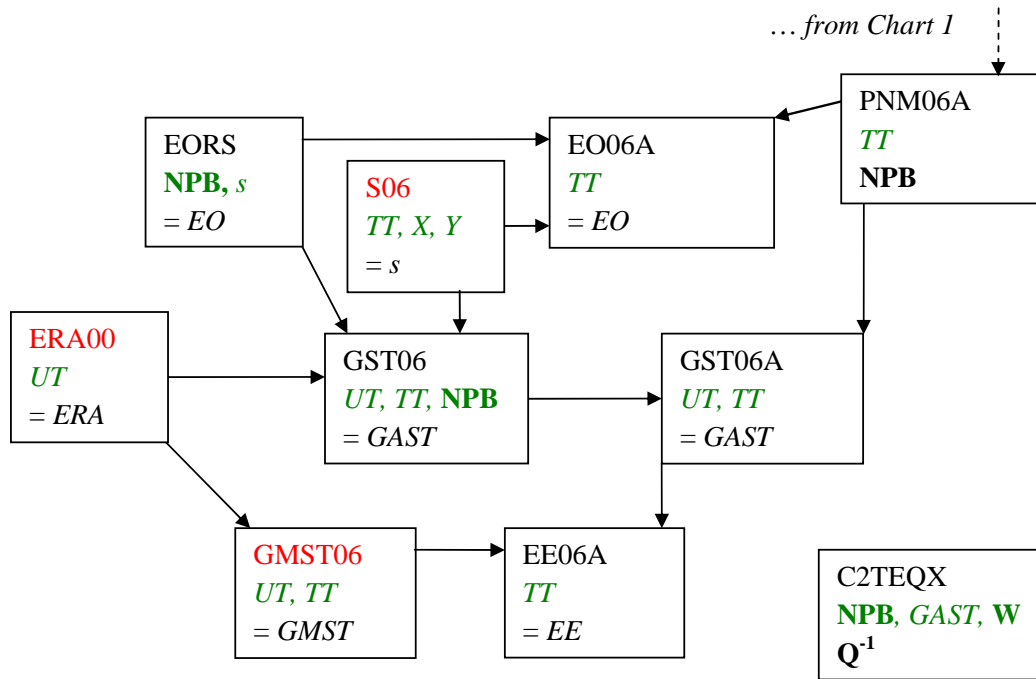
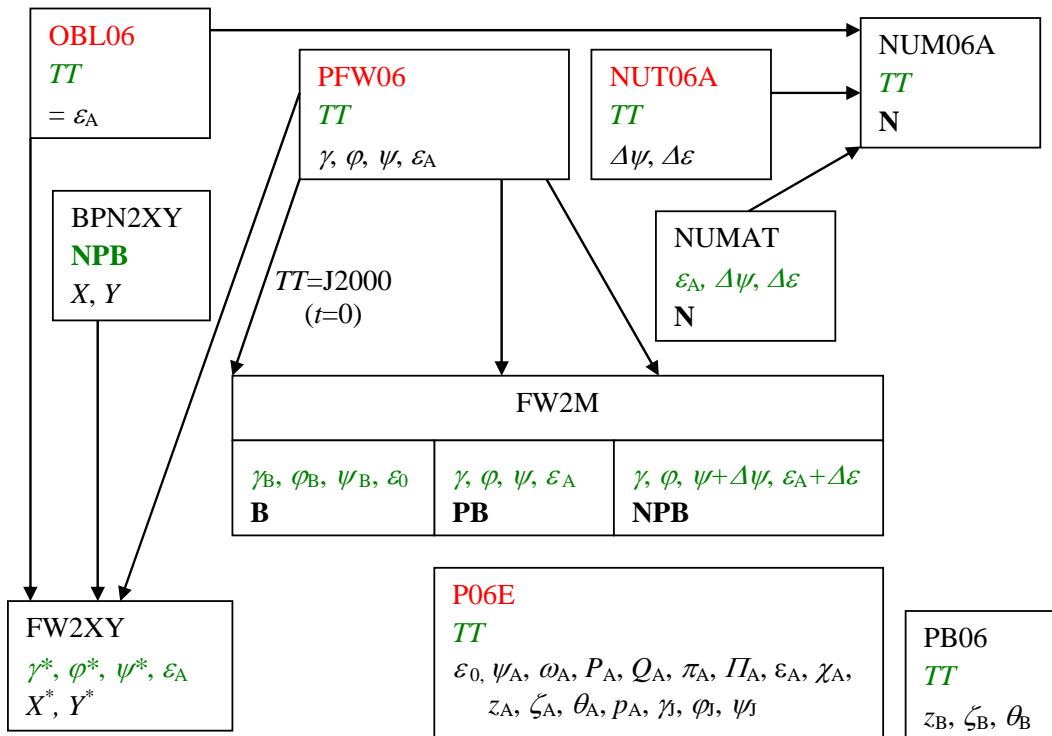

Chart 3: Routines for bias, precession and nutation; not all are shown in Chart 1.



* The arguments supplied by the user may be any of the three sets given for FW2M.

IAU 2006/2000A SOFA ROUTINES

NOTES

CIO based

$$\begin{aligned} [\text{ITRS}] &= \mathbf{W} \mathbf{R}_3(\theta) \mathbf{C} [\text{GCRS}] \\ &= \mathbf{Q}^{-1} [\text{GCRS}] \end{aligned}$$

Equinox based

$$[\text{ITRS}] = \mathbf{W} \mathbf{R}_3(\text{GAST}) \mathbf{NPB} [\text{GCRS}]$$

Symbol	Quantity	Rotation from / to	
Equinox based			
B	Bias	ICRS to the mean equator and equinox of J2000.0.	GCRS → J2000
P	Precession	J2000.0 to mean equator and equinox of date.	J2000 → Mean of date
N	Nutation	Mean equator of date to true equator and equinox of date.	Mean of date → True of date (EES)
R₃(GAST)	Greenwich apparent sidereal time	True equator and equinox of date to the Terrestrial Intermediate Reference System.	EES (True of date) → TIRS
NPB			GCRS → True of date
CIO based			
C	Bias, precession-nutation	GCRS to Celestial Intermediate Reference System (true equator of date).	GCRS → CIRS
R₃(θ)	Earth rotation angle	CIRS to the Terrestrial Intermediate Reference System.	CIRS → TIRS
Q⁻¹ Q		GCRS to the Terrestrial Intermediate Reference System.	GCRS → ITRS ITRS → GCRS
Terrestrial			
W	Polar motion:	TIRS to the International Terrestrial Reference System; includes R ₃ (s′).	TIRS → ITRS